



CP MULTITHERM D.A

Electric heater



1 Application

Heating of instrument enclosures in hazardous areas, designed for

- freeze protection
- condensation protection
- temperature maintenance
- vertical installation

2 Special Features & Advantages

- availability of standard items from stock
- short delivery times
- vertical design allows for optimum installation adjacent to the instruments to be heated in the enclosure
- freeze-protection thermostat (TS) integrated as standard in the connection cable or protective thermostat (TS40) for temperature maintenance
- high heat output resulting from a special, black anodized aluminium profile construction

3 Description

The very versatile MULTITHERM line consists of electric heaters designed to heat the air in the enclosure by convection.

Wherever possible, a heater designed for temperature class T3 should be selected. A temperature limiter is integrated in the heater that cuts off the power in case of a technical failure or excessive heating resulting from an external heat source. It should be noted that the temperature limiter must only be repaired in our factory. For reasons of operational safety the heater must only be operated under conditions that ensure that the trip temperature of the limiter will not be exceeded:

- Ensure effective convection by observing the necessary clearances as per sections 7 on the next page. Allow for good convection circulation in the enclosure and take care not to cover the fins.
- The TS thermostat supplied as standard will limit the ambient temperature in the housing.
- For temperature maintenance an additional external thermostat type TAE must be connected in series with the heater. It should be mounted on top of the heater surface to ensure thermal feedback (see 7.2).
- Alternatively a TC temperature controller can be used.

With regard to the residual current devices and insulation monitors, attention must be paid to DIN EN 60079-14:2014 and/or the operating instructions.

A temperature indicator shows potential problems and failures at an early stage (e.g. incorrect installation). Please check the application if more than 3 fields have irreversibly changed to black.



All INTERTEC explosion-proof heaters can also be supplied

- to North American standard (CSA/NEC/NRTL)
- in a less expensive, Non-explosion-proof design
- as Bi-Standard (see datasheet [HD508](#))



4 Explosion Protection

EC Examination Certificate	PTB 02 ATEX 1041 X
IEC Scheme Certificate	IECEX PTB 07.0052X
IEC Scheme Type of Protection	II 2G Ex db IIC T6,T5,T4,T3
	II 2D Ex tb IIIC T85°C, T100°C, T135°C, T200°C

5 Technical Data

Ingress Protection	IP68
Nominal voltage	230V AC (220-240 V AC)
Operating temp. range	-60°C to 180°C
Connection cable	silicone cable, notch and oil resistant 3x1,5mm ² , Ø8,8mm
Length of connection cable	1 m
Dimensions, (W x D)	80 x 80 mm
Material	seawater-proof aluminium, black anodized

CP MULTITHERM DNA	50 T4	75 T4	100T3*	150T3
Temperature class	T4	T4	T3	T3
Nominal power [W]	50	75	100	150
Height	155 mm			

CP MULTITHERM DPA	100 T4	200 T3	250 T3
Temperature class	T4	T3	T3
Nominal power [W]	100	200	250
Height	225 mm		

*This type of heater is also available with a protective thermostat TS40 integrated in the connection cable for temperature maintenance up to 40°C. Room temperature control must be effected by an additional TAE thermostat or TC temperature controller. (Other types upon request)

6 Options

TS40 (with*)	Protective thermostat
AM	Failure alarm opening at < 5 °C silicone cable, notch and oil resistant 5x1,0 mm ² Ø8,5 mm
3M	Connection cable 3 m long
120 V, 24 V	Nominal voltage 120 V, 24 V AC/ DC
250V	Nominal voltage 250V AC (245-265 V AC)

Not all options can be combined.



CP MULTITHERM D.A

Electric heater



7 Installation, Minimum Clearances

During installation, attention should be paid to the following:

- installation and operating instructions supplied with the heater MULTITHERM
- The fins must be positioned vertically
- Please note minimum clearances to the enclosure, as per 7.1.1 and 7.1.2
- For temperature maintenance install the TAE thermostat on the heater, see 8.2
- The label must be clearly legible

The INTERTEC universal mounting bracket supplied with the heater is very versatile and bolts and nuts are included in the mounting kit.

7.1 MULTITHERM TS

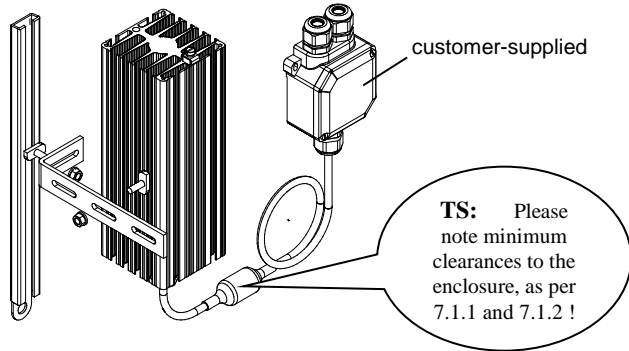

7.1.1 with customer-supplied internal junction box

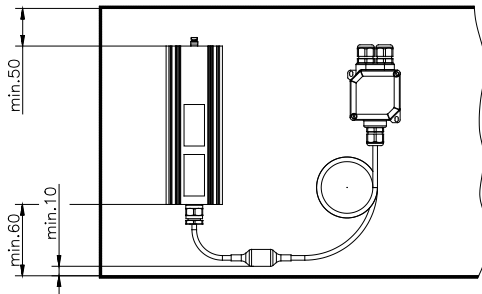

7.1.2 with customer-supplied external junction box

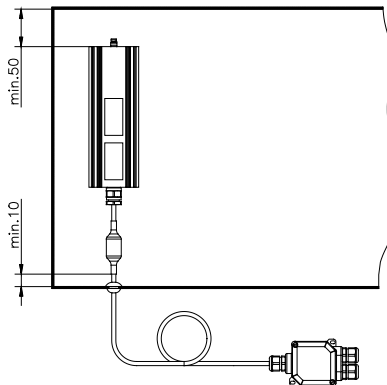

7.2 MULTITHERM TS40 with TAE

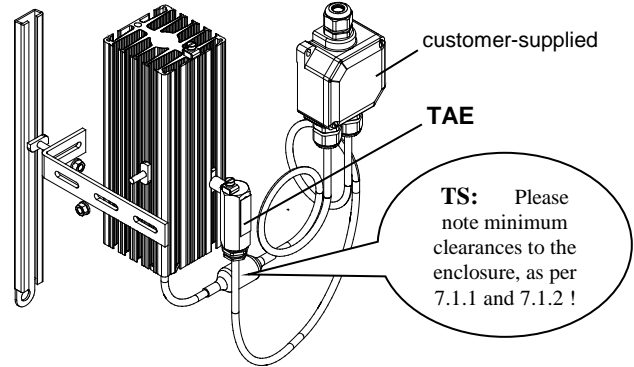

8 Wiring Diagramme

8.1 MULTITHERM TS

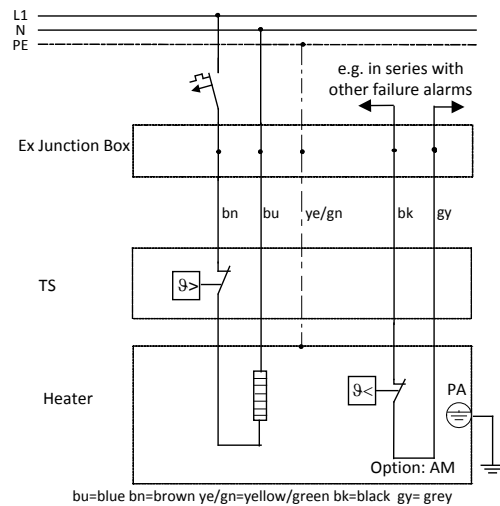

8.2 MULTITHERM TS40 with TAE

